

O W N E R ' S M A N U A L



PARASOUND

ZoneMaster Z-12 High Current Amplifier

Table of Contents

Important Safety Instructions	3
Figure #1 Zonemaster Z-12 Front and Rear Panel Drawings	4
Introduction	6
Installing and Rack Mounting	6
Ventilation Requirements	6
Connecting the Zonemaster Z-12	7
Speaker Connections	9
Automatic Turn On Options	11
AC Power Connections and AC Grounding	12
Operating Your Zonemaster Z-12	12
Maintaining Your Parasound Amplifier	13
In Case of Trouble.....	14
Parasound Zonemaster Z-12 Specifications	16

Special Features of the Parasound Zonemaster Z-12

50 Watts Per Channel into 8 Ω , Less than 0.2% THD
100 Watts Per Channel Pair Bridged into 8 Ω , Less than 0.2% THD
10 Amperes Peak Current Per Channel
Direct Coupled with DC Servo Circuitry
Encapsulated 1.2 kVA Toroidal Power Transformer
120,000 μ F Distributed Power Supply Capacitance
24 Discrete High Speed Output Transistors
Automatic Power On-Off by 9 V to 12 V Trigger or Audio Signal
Occupies Four Rack Spaces in a 19-inch Equipment Rack
Modular Construction
Multiple Relay Protection
Level Controls for Each Channel
Gold-Plated RCA Input Jacks
Gold-Plated 5-Way Speaker Terminals
Impedance Protection Switches
Left and Right Input Buses
Looping Output Connectors
Current Overload Indicators
Rear Carry Handles
Removable IEC AC Cord

IMPORTANT SAFETY INSTRUCTIONS



The lightning flash with the arrowhead symbol within an equilateral triangle is intended to alert the user to the presence of “dangerous voltage” inside the product that may constitute a risk of electric shock.



The exclamation point within an equilateral triangle is intended to alert the user to the presence of important operating and maintenance instructions in the literature accompanying the product.

TO REDUCE THE RISK OF ELECTRIC SHOCK, DO NOT REMOVE COVER. NO USER-SERVICEABLE PARTS INSIDE. REFER SERVICING TO QUALIFIED SERVICE PERSONNEL

- 1. Read Instructions** — Read all the safety and operating instructions before operating this product.
- 2. Retain Instructions** — Retain safety and operating instructions for future reference.
- 3. Heed Warnings** — Adhere to all warnings on the product and in the operating instructions.
- 4. Follow Instructions** — Follow all operating and use instructions.
- 5. Cleaning** — Unplug this product from the wall outlet before cleaning. Use a damp cloth for cleaning. Clean the outside of the product only.
- 6. Attachments** — Do not use attachments that are not recommended by the product manufacturer; they may be hazardous.
- 7. Water and Moisture** — Do not use this product near water.
- 8. Accessories** — Do not place this product on an unstable cart or stand. The product may fall, causing bodily injury and damage to the product. A product and cart combination should be moved with care. Quick stops, excessive force, and uneven surfaces may cause the product and cart to overturn.
- 9. Ventilation** — Slots and openings in the cabinet are provided for ventilation to ensure reliable operation of the product and to protect it from overheating. These openings must not be blocked or covered. *This product should not be placed in a built-in installation such as a bookcase or rack unless proper ventilation is provided.*
- 10. Power Sources** — Operate this product only from the type of power source indicated on the label. If you are not sure of the type of power supply to your home, consult your dealer or local power company. This product is equipped with a three-prong grounding plug. This plug will only fit into a grounding power outlet. If you are unable to insert the plug into the outlet, contact your electrician to replace your obsolete outlet. Do not defeat the safety purpose of the grounding plug.
- 11. Power Cord Protection** — Power supply cords should be routed so that they are not likely to be walked on or pinched by items placed upon or against them.
- 12. Lightning** — Unplug the unit from the wall outlet for added protection during a lightning storm and when it is left unattended and unused for long periods of time. This will prevent damage to the product due to lightning and power line surges.
- 13. Overloading** — Do not overload wall outlets or extension cords. This can result in a fire or electric shock.
- 14. Inserting Objects into Unit** - Never push objects of any kind into this product through any openings; they may touch dangerous voltage points or short out parts that could result in fire or electric shock.
- 15. Servicing** — Do not attempt to repair or service this product yourself. Opening or removing covers may expose you to dangerous voltage and other hazards. Refer all servicing to qualified service personnel.
- 16. Damage Requiring Service** — Unplug this product from the wall outlet and refer servicing to qualified service personnel under the following conditions: a) If the power-supply cord or plug is damaged. b) If liquid has been spilled into the product. c) If the product has been exposed to rain or water. d) If the product does not operate normally by following the operating instructions. e) If the product has been dropped or damaged in any way. f) If the product exhibits a distinct change in performance.
- 17. Replacement Parts** — When replacement parts are required, be sure the service technician has used replacement parts specified by the manufacturer. Unauthorized substitutions may result in fire, electric shock, and other hazards.
- 19. Safety Check** — Upon completion of any service or repairs to this product, ask the service technician to perform safety checks to determine that the product is in proper operating condition.
- 20. Wall or Ceiling Mounting** — Mount the product to a wall or ceiling only as recommended.
- 21. Heat** — The product should be situated away from heat sources such as radiators, heat registers, stoves, and other products (including amplifiers) that produce heat.

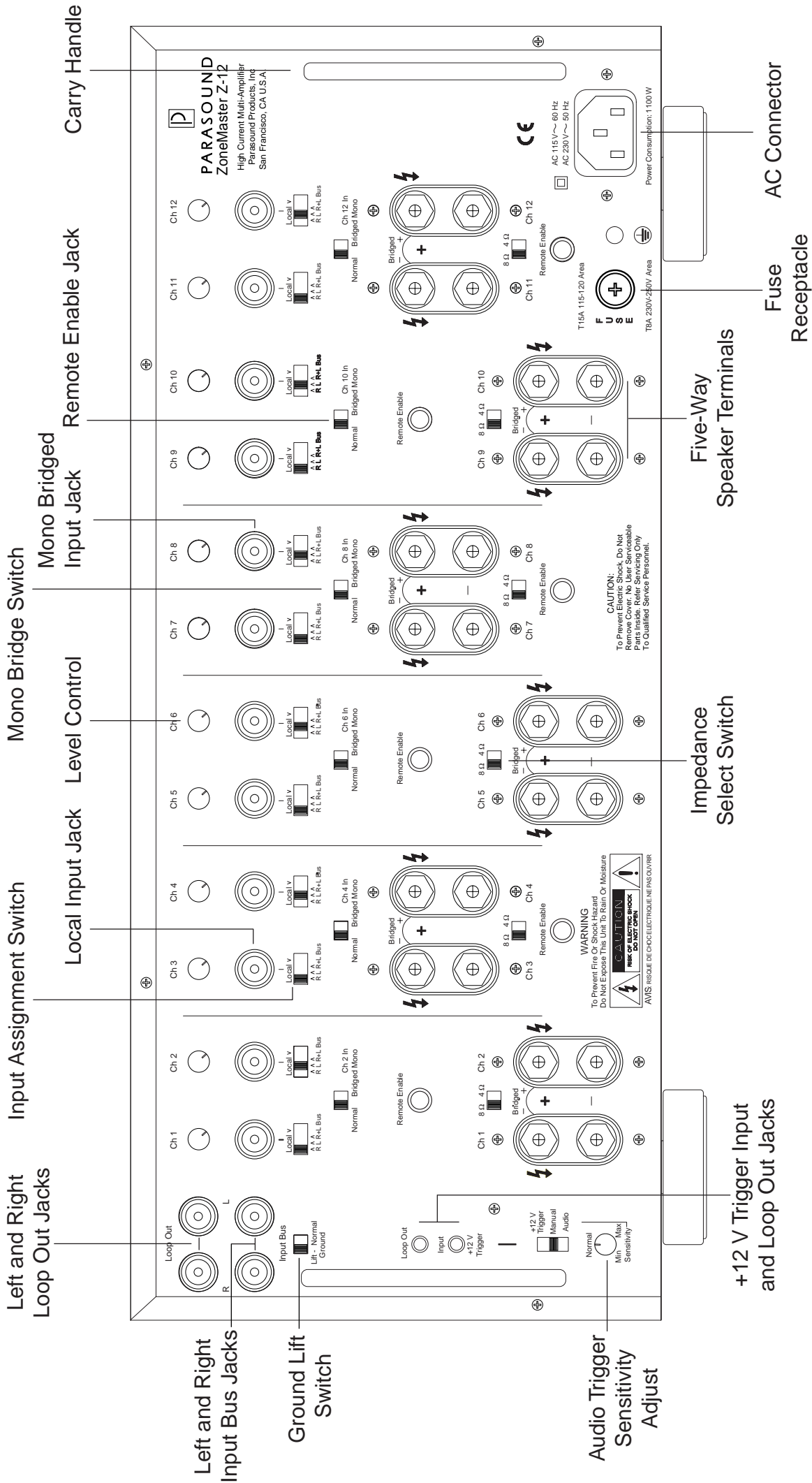

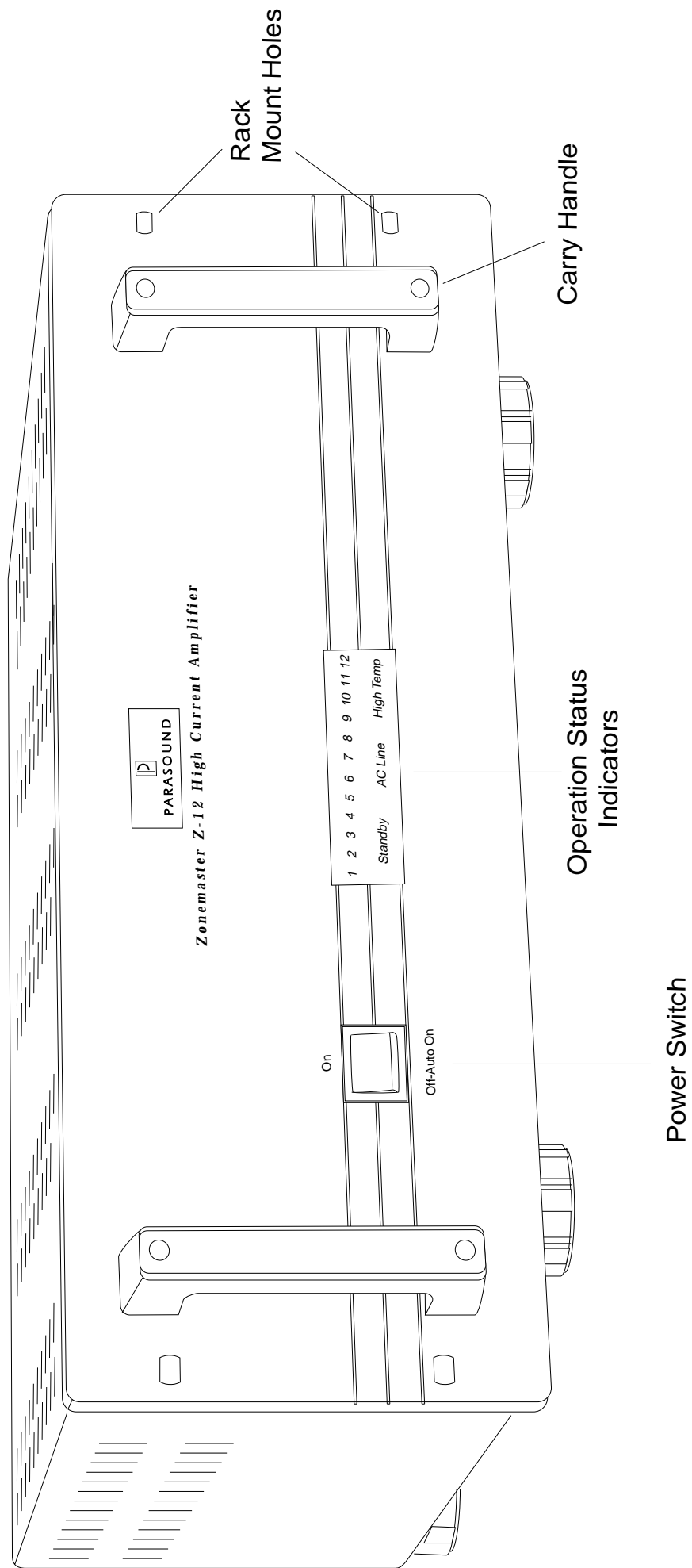

Introduction

Congratulations on your purchase of this precision audio component and thank you for your selection of Parasound. The Parasound Zonemaster Z-12 was designed to drive up to twelve speakers in multi-room and multi-zone applications. The incredible versatility of the Zonemaster Z-12 allows many connection and configuration options, so please be sure to read this manual thoroughly before you begin installation.

Unpacking

Carefully unpack your Zonemaster Z-12 and remove the enclosed AC power cord, the sub-mini 2.5 mm trigger connection plug and wire, and the package of 24 banana plugs. Be sure to inspect the unit for any possible shipping damage. If you notice any, contact your Parasound Dealer immediately. Save the carton and all of the packing materials in case you ever need to ship your amplifier for repair. Before you proceed, locate the serial number on the rear panel of your amplifier and record it here for future reference:

Serial # _____ Date of Purchase _____

Parasound Dealer _____ Phone Number _____

Installation and Rack Mounting

Install your Z-12 away from heat sources such as heating ducts and radiators. Always mount the amplifier horizontally and make sure that your cabinet or shelf can support its weight.

You should provide a separate shelf for your Zonemaster Z-12 rather than stacking it directly above or below other components.

The Z-12 front panel occupies four rack spaces (7") in a standard 19" equipment rack. When rack mounting, have someone help support the unit while you bolt its front panel to the rack rails. Be sure to use heavy duty mounting bolts and nylon shoulder washers on both sides of the faceplate to avoid ground loops.

For any additional rack mounting hardware you may need, Parasound recommends Middle Atlantic Products, (201) 839-1011.

Ventilation Requirements

The Zonemaster Z-12 is capable of substantial power output, and a fair amount of heat dissipation is normal. The Z-12 requires *plenty of ventilation* to prevent overheating and shut down by its thermal protection circuits. Observe the following ventilation guidelines when installing the Z-12 in a cabinet or other enclosed area:

- 1) If you are not using a ventilation fan, allow at *least* six inches on each side of the unit and 12" above it. You should *never* install the Z-12 in an unventilated equipment cabinet with a door or panel because hot air cannot circulate and exhaust adequately.
- 2) If you choose to mount the Z-12 in an equipment cabinet, two vent holes are required in the cabinet: one for intake and one for exhaust. Use a fan to draw in cool air from below and to exhaust warm air above the unit.

- 3) Do not place the Z-12 on carpeting or any other material that could obstruct airflow through the ventilation holes in the bottom of its chassis.
- 4) Never stack the Z-12 between other components because hot air will quickly become trapped and cause overheating of the amplifier and the other units. It's best to mount the Z-12 above your other components.

Connecting the Zonemaster Z-12

Refer to the drawing on Page 4

Connection Precautions

Leave the AC cord disconnected before and while making or changing any input, trigger, or speaker connections. Make sure there is no strain or tension on any connections that could cause them to eventually pull loose.

Input Connections & Input Assignment Switches

You can select or “assign” different inputs to each of the twelve amplifier channels. The four position Input Assignment Switches designate the source from which each channel receives its signals.

You can assign each input to receive its signal from the Main Left Input or Main Right Input, a mono sum of both the Left and Right Inputs, or its independent input jack.

Input Assignment Switch Position	Signal Origin
L	Left Input Bus
R	Right Input Bus
L+R	Left and Right Input Buses, mixed to mono
Local	The RCA Input jack for each channel

Main Left and Right Input Connections

The Left and Right Input jacks feed two signal paths (“buses”) that are distributed to all twelve amplifier channels. The Input Assignment switches let you choose whether each of the twelve amplifier channels receive an input from the Left or Right Input Bus or a mono sum of the Left and Right Input Buses.

Looping Output Connections

The Right and Left Loop Out jacks provide a convenient way to connect an additional amplifier to receive the same input signals as the Right and Left Main Inputs. Once you have connected a source to the Z-12 Main In jacks you can connect the Loop Out jacks to the input jacks of an additional amplifier. This feature eliminates the need for a “Y” connector between your source, the Z-12, and the other amplifier.

Independent Input Connections

Each channel has its own Local RCA input jack which is independent from the main Left and Right input buses. To assign an amplifier channel to its independent input, move its Input Assignment Switch to the furthest right Local position.

In the other three positions of this switch the amplifier channel will receive its signal from the Left and/or Right Input Bus.

Examples of Input Configurations

Example 1: Configure a zone for stereo operation using Ch 1 and Ch 2.

1. Connect the left and right channel outputs from the system controller to the Left and Right Main Input (Bus).
2. Set the Ch 1 Input Assignment switch to its L position.
3. Set the Ch 2 Input Assignment switch to its R position.
4. Connect Ch 1 Speaker Terminals to the left speaker.
5. Connect Ch 2 Speaker Terminals to the right speaker.

Example 2: Configure mono operation in two rooms in a zone using Ch 3 and Ch 4:

1. Connect the left and right output of the system controller to the Left and Right Input Bus.
2. Set the Ch 3 Input Assignment switch to its R+L position.
3. Set the Ch 4 Input Assignment switch to its R+L position.
4. Connect the Ch 3 Speaker Terminals to the speaker in room 1.
5. Connect the Ch 4 Speaker Terminals to the speaker in room 2.

Example 3: Configure stereo operation in a zone with independent inputs using Ch 5 and Ch 6.

1. Connect the left output of the source to the Ch 5 Local input jack.
2. Connect the right output of the source to the Ch 6 Local input jack.
3. Set the Ch 5 Input Assignment switch to its Local position.
4. Set the Ch 6 Input Assignment switch to its Local position.
5. Connect the Ch 5 Speaker Terminal to the left speaker.
6. Connect the Ch 6 Speaker Terminal to the right speaker.

Impedance Select Switch

The impedance select switch helps to prevent the Z-12 from overheating with low impedance loads. This is accomplished by lowering the internal DC supply voltage.

If either channel of a channel pair (1 & 2, 3 & 4, 5 & 6, etc.) is connected to a 4 Ω speaker load (one 4 Ω speaker or two 8 Ω speakers, select 4 Ω).

If both channels of the channel pair are connected to an 8 Ω load, select 8 Ω .

Speaker Connections

Five-Way Speaker Terminals

You can connect bare wire up to AWG 12, speaker wire terminated with 1/4" spade lugs, or banana plugs (provided) to the 5-way speaker terminals. The terminal positions are staggered to give you more room to make connections using bare wire or spade lugs.

If you use bare wires, remove only enough insulation so the exposed bare wire can fit through the hole in the terminal's binding post. Before inserting the wire, twist its strands between your fingers tightly to prevent strays that might cause a short circuit. You may want to "tin" the stripped bare wire with solder to prevent it from fraying and oxidizing.

Observing Correct Polarity

When you connect speakers to your amplifier, you will notice that one side of each two-conductor speaker wire is marked with something to let you know which wire to connect to the positive and which to connect to the negative speaker terminals at each amplifier channel and speaker. Speaker wires are usually coded with printing or ridges on the insulation of one of the two leads. Be sure to be consistent with polarity throughout the installation.

Terminating the Banana Speaker Plugs

Your Z-12 includes 24 gold-plated brass banana plugs for use with all 12 channels. They accept wire up to AWG 12. To properly terminate the banana plugs, follow these steps:

1. Remove the insulating boot from the banana plug and slide it up onto one of the speaker wires. Be sure to use the red boot for the positive wire and the black boot for the negative wire.
2. Strip a half an inch of insulation from the speaker wire and insert it into the barrel of the banana plug. If you are using a AWG 16 or thinner, you should strip one inch of insulation from the speaker wire and bend the exposed wire back on itself to make a fatter bundle before inserting into the barrel of the banana plug.
3. To insure the best connection, allow solder to melt into the barrel by heating it from the outside.
4. If you don't solder you can use a crimping tool or a vise grip to crimp the barrel of the plug onto the wire. Part of the barrel may split, but as long as the wire is held firmly this isn't a problem and the rubber-insulating boot will cover it.
5. Test the solder or crimp by firmly trying to pull the wire out of the barrel.
6. Slide the insulating boot over the barrel.

Bridged Mono Operation

Each channel pair of the Zonemaster Z-12 can be configured for bridged mono operation. **IMPORTANT!** You must set the Input Assignment Switch to the Local position for both channels of the channel pair you wish to operate in the bridged mode.

We recommend an 8 Ω minimum speaker load for each channel pair you operate in the bridged mode. When bridging, the Impedance Select Switch should also be set to its 4 Ω position.



This recommendation results from the mathematics of bridged mono operation. In the mono mode each amplifier channel functions for only the positive or negative half of the audio waveform. As a result, each channel “sees” only *half* of the speaker’s rated impedance.

Use of an 8 Ω speaker results in a load impedance of only 4 Ω per channel.

Use of a 4 Ω speaker results in a load impedance of only 2 Ω per channel and is not recommended.

Rear Panel Bridged Mono Switch

Set the Bridging Switch to its Bridged Mono (right) position for each channel pair you wish to bridge. The power should be off before moving this switch.

Stereo output will be weak and distorted if you accidentally leave the Mono Bridge switch in its Bridged Mono position and you try to connect speakers in the stereo mode.

Example 4: Configuring a channel pair to operate in the Bridged Mono operation.

1. Set *both* Input Assignment Switches of the channel pair to Local.
2. Set the Impedance Select Switch for the channel pair 4 Ω .
3. Connect the left output of the system controller to the even number (Ch 2, Ch 4, Ch 6, etc.) input jack of the channel pair.
4. Connect the positive lead of the speaker cable to the red even number channel (Ch 2, Ch 4, Ch 6, etc.) speaker terminal of the bridged channel pair.
5. Connect the negative lead of the speaker cable to the red odd number channel (Ch 1, Ch 3, Ch 5, etc.) speaker terminal of the bridged channel pair.
6. Use the even number channel Level control to adjust the bridged channel pair gain.

Remote Enable Function

The remote enable feature lets a system controller totally activate and deactivate the six channel pairs of the Z-12 (Ch 1-2, Ch 3-4, Ch 5-6, Ch 7-8, Ch 9-10, and Ch 11-12).

To use this feature, plug a wire with a 1/8” (3.5 mm) 2 channel mini plug into the Remote Enable Jack for the channel pair you want to activate independently. Connect the other end of the wire to the relay module that will activate the channel pair of the Z-12. Refer to the controller manufacturer for proper use and termination required for the relay module.

Important Notes:

1. The Remote Enable jacks do not require or accept a 12 V trigger voltage, unlike the main Auto On 12 V trigger jack. All that is required is to make a “dry contact” between the two wires that are attached to the plug which inserts into the Remote Enable Jack to activate that channel pair.
2. If you insert a plug into the Remote Enable jack, that channel pair cannot function until its wires are connected to each other by the system controller.



Ground Lift Switch

The Ground Lift Switch isolates the input signal ground from the chassis ground. This often helps eliminate ground loops that result from a different electrical ground potential between the Z-12 and other components connected to it.

In the Normal position, the input ground is connected to chassis ground. In the Lift position, the input ground is disconnected, or “lifted” from chassis ground.

Automatic Turn On Options

For automation and convenience, the Z-12 can be turned on and off by applying a trigger voltage or by the presence of an audio signal at the Main Left and Right RCA input jacks.

Auto On Select Switch

In the upper position of the Auto On Switch, the Z-12 is turned on and off with an external +9 V to +12 V trigger voltage.

In the middle position of the Auto On Switch, the auto on function is disabled and the Z-12 can only be turned on and off manually by the Power Switch on its front panel.

In the lower position of the Auto On Switch, the Z-12 is turned on and off when an audio signal is present at the main Left and Right Input jacks.

Trigger Input Connection

The Z-12 can be triggered on with an external DC voltage source that ranges from between +9 V and +12 V. Many audio video controllers such as the Parasound AVC-2500 have trigger outputs for this task.

To activate the Z-12 with an external voltage source, connect one end of the provided 2.5 mm sub-mini plug to a +9 V to +12 V source and the other end to the +12 V Trigger Input of the Z-12.

With a DC voltage source, the trigger plug tip must be positive and its sleeve negative. The trigger circuit is optically coupled and requires only 15 mA of current to be activated.

Trigger Loop Out Connection

The Trigger Loop Output jack lets you “daisy chain” the trigger source to additional amplifiers and other components. Once you have connected the trigger source to the Z-12 Trigger Input Jack, a second 2.5 submini plug inserted into the Trigger Loop Out jack will route it to additional components.

Audio Trigger Sensitivity Adjustment

The Auto On Audio Sensitivity Control adjusts the signal level required to turn the Z-12 on with an audio signal. You can adjust the audio trigger sensitivity level from 20 mV (fully counterclockwise) to 200 mV (fully clockwise). There is a detented notch in the center position corresponding to 70 mV that should be a suitable in most cases.

AC Power Connections and AC Grounding

Before you connect the AC cord, make sure your Z-12's front panel Power Switch is in its off position and any external auto on trigger source is inactive.

If possible, plug your Z-12 directly to the same AC outlet that powers your accompanying audio components and the system controller. If you don't use the same AC outlet, you will likely encounter 60 Hz (domestic, 50 Hz abroad) hum from the differing ground potentials between the AC outlets.

Operating the Zonemaster Z-12

Refer to Drawing on Page 5

Power Switch

Manual Turn On

Press the upper half to turn the unit on manually; press the lower half to turn the unit off.

Automatic Turn On

When the Power Switch is in its Off position, your Z-12 can still be turned on with an external voltage applied to its Auto On Trigger Jack. Both Manual On and Auto On turn on power to the entire amplifier, although they do not necessarily activate individual channel operation (See Remote Enable).

Level Controls

Each channel has its own rear mounted "set and forget" input Level Control. Depending on how you have configured the Z-12, you can use these controls to properly match the levels from zone to zone or channel to channel. Each channel is marked on the top cover, to identify levels without having to actually go behind the unit to view the Level controls.

Front Panel Indicators

AC Line Indicator

The amber AC Line indicator on the front panel lights when the AC power cord is connected to a live AC source. It makes system troubleshooting simpler.

Standby Indicator

When the Z-12 is turned on, manually or automatically, the red Standby indicator will light while its internal circuits are stabilizing and no audio signal will pass. After about five seconds, the Standby indicator will turn off when the amplifier is operational.

The red Standby indicator will also light when an external or internal fault activates the Z-12 protection circuitry for any channel pair. Remove power to the amplifier and check the speaker connections for a short circuit. During this time, the protection circuits should automatically reset. If Standby remains lit after overload conditions or faulty speaker connections are corrected, it may indicate an internal fault. If this occurs, contact your Parasound Dealer, Installer or Parasound Technical Service for further advice.

High Temp Indicator

The High Temp indicator will light red when the any of the six internal heatsinks reach 90 degrees centigrade. If *either* channel in a channel pair is driven beyond its safe thermal range, the High Temp indicator will light red and both channel pair numbers in the front panel display will change from green (normal) to red (fault).

Both channels on a shared heatsink will shut down until the heatsink temperature falls below 90 degrees centigrade, at which time the amplifier channel pair will automatically resume normal operation. The Z-12 is unlikely to overheat unless it is deprived of adequate ventilation.

Channel Status Indicators

The display window on the front panel provides complete operational status of each channel pair (1-2, 3-4, 5-6, etc.) of the Zonemaster Z-12. The following chart shows front panel indication and the corresponding status of the channel pair.

Channel Pair LED Indication	Corresponding Channel Pair Status
Green illumination	Normal operation
Red illumination	A fault with one or both channels in the channel pair Temperature overheating Channel(s) are being overdriven Load impedance too low or short circuited wires Blown internal B + or B- fuse(s)
LEDs not illuminated	Remote enable is disabled by the system controller

Maintaining Your Parasound Amplifier

Your Parasound power amplifier requires no periodic maintenance and has no user serviceable parts inside. To avoid the risk of electric shock, do not remove the top cover. The amplifier's exterior can easily be cleaned with a soft cloth moistened only with a few drops of water or glass cleaner.

Main Power Fuses

There is an external fuse mounted on the rear panel. This fuse protects the unit from possible damage to internal parts.

Each channel pair has its own B+ and B- fuses that may open when there is a repeated fault at the speaker output. This could occur when the speaker cable is short-circuited, or the impedance to that channel is too low.

If you suspect that the B+ or B- fuses may be blown, have qualified service personnel inspect or replace these fuses since dangerous voltages are present in this amplifier.

Never replace any fuse with a higher value than originally installed. Substitution of larger fuses may seriously damage internal parts and will void your warranty.

In Case of Trouble

If you suspect a problem with your Z-12, first turn the amp off and check all your connections. Another component or even a defective hookup cable may cause the trouble. If you hear hum, turn off the amplifier and disconnect the inputs to it. If the hum is gone when you turn the amplifier back on, it was probably caused by your preamplifier, system controller, or one of the source components connected to it.

Also, make sure that the AC cords of all components are connected to the same AC outlet. In rack mounted systems, ground loops and hum will often develop via ground loops caused by redundant grounding of the metal rack rails of the equipment rack. This problem is usually solved with nylon insulating shoulder washers (refer to the Rack Mounting section in this owner's manual).

If All Else Fails

Call your Parasound dealer or Parasound Technical Service Department. We can usually suggest other diagnostic tests you can easily perform. If we determine that your Z-12 should be returned to Parasound or an Authorized Parasound Warranty Center for inspection and possible servicing, call Parasound for the location of a warranty center near you or shipping instructions for return to Parasound.

Returning your Z-12 to Parasound for Service

If we determine that you should send your Zonemaster Z-12 to Parasound, you will need to obtain a Return Authorization (RA) number. The RA number must be clearly marked on the outer carton only. Ship the unit with adequate insurance and a copy of your purchase receipt inside to validate your warranty. You must provide an original purchase receipt from an Authorized Parasound Dealer for warranty repair. Units purchased from unauthorized dealers are not eligible for warranty repair.

Units that arrive without an RA number, without a suitable shipping carton or with evidence of improper internal packing materials may be refused. We do not accept collect shipments. After repair under warranty, the unit will be returned to you via prepaid UPS within the Continental United States.

In the case of a non-warranty repair, contact us and we will advise you of the repair charges before you ship the unit to us. The same packing and Return Authorization number requirements apply.

Important Notice before Shipping your Z-12

Before you ship the unit to Parasound, you **MUST** repack the unit into its fitted foam insert sandwich and its original carton. Use of any other carton and packing materials will probably result in shipping damage. Common carriers such as UPS will not pay claims for damage incurred during shipment when products are surrounded only with styrofoam "peanuts" or placed in non-original factory cartons.

Repairs for shipping damages because of mis-packing are your sole responsibility. If you do not have the original packing cartons and foam inserts, call us for new packing material that we can provide to you at a nominal charge.

Parasound Zonemaster Z-12 Specifications

Continuous Power Output

50 watts RMS x 12, 20 Hz - 20 kHz into 8 Ω

50 watts RMS x 12, 20 Hz - 20 kHz into 4 Ω

100 watts RMS, 20 Hz - 20 kHz into 8 Ω per bridged channel pair

Current Capacity

10 amps peak per channel

Slew Rate

>90 V/microsecond

Frequency Response

20 Hz-20 kHz, +/- 0.25 dB

Total Harmonic Distortion

< 0.2 % at full power; < 0.05 % typical levels

IM Distortion

< 0.03 %

TIM

Unmeasurable

Dynamic Headroom

> 1.5 dB

Interchannel Crosstalk

> 50 dB at 1 kHz

> 40 dB at 20 kHz

Input Impedance

47 k Ω for each channel

Input Sensitivity

1.2 V for full output

S/N Ratio

> 86 dB, input shorted, IHF A-weighted

Damping Factor

> 800 at 20 Hz

12 V Trigger Current Requirements

15 mA

Audio Trigger Sensitivity Range

20 mV to 200 mV

Dimensions

19" wide x 7" high x 17 1/4" deep (7 5/8" high with feet)

Power Requirements

110-120 Vac 1100 Watts

Features and specifications subject to change without notice



PARASOUND

*Parasound Products, Inc. 950 Battery Street, San Francisco, CA 94111
415-397-7100 / FAX 415-397-0144 www.parasound.com*

© 2000 Parasound Products, Inc. Rev 1.1